

Neles Easyflow™ full bore flanged ball valve

Series J9

J9 series full bore flanged seat supported ball valve provides long, reliable performance. Rugged two-piece body construction with dual seal body design withstands heavy piping loads and wide temperature fluctuations. Spring loaded v-ring packing provides extremely long cycle life with minimum maintenance. Direct actuator mounting capability makes it easy to automate with accurate alignment. Complete package reliability and single source responsibility with actuators, switches, and intelligent valve controllers. Cavity fill option for the J9 series ensure lowest possible dead volume in the ball cavity between the seats.

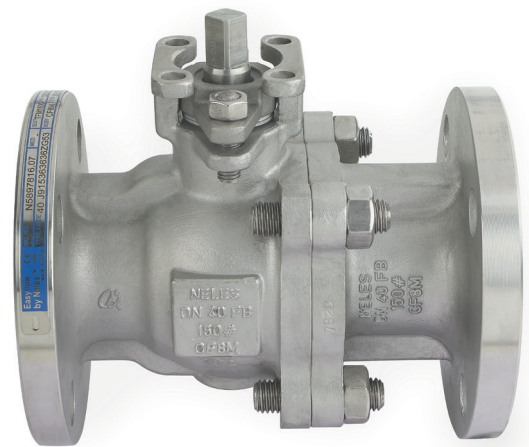

Technical description

- Sizes DN15 to 200 (NPS 1/2 to 8)
- ASME Class 150 or Class 300
- Rugged two-piece body construction
- Live-loaded stem packing
- Bi-directional bubble-tight shut-off to full rated pressure
- Suitable for vacuum service

Features

- Unique low torque seat design maintains tight shut-off through pressure and temperature cycles
- ISO 5211 mounting pad for direct mounting of hand lever, gear operator, manual override, or actuator
- Internal entry blow-out proof stem design
- Spring loaded stem seal provides long cycle life and low emissions with minimal maintenance
- An extremely tight fit drive between the stem and ball ensures accurate and repeatable shut-off and control

- Anti-static grounding between ball and stem as well as stem and body is standard
- Available with lockable hand lever
- Cavity fill option minimizes media trapped in the cavity between the seats when the valve is open
- Every valve is factory tested, serialised & quality tagged prior to shipment
- CE marked for the European Pressure Equipment Directive (PED) 2014/68/EU as standard
- API 607 fire safe qualified
- SIL-3 qualified

Applications

- Chemical and petrochemicals
- Pulp & paper
- Food and beverage
- Water & wastewater
- Pharmaceutical
- HVAC
- Mining

Exploded view and parts list

DN15 to DN200 two-piece body construction

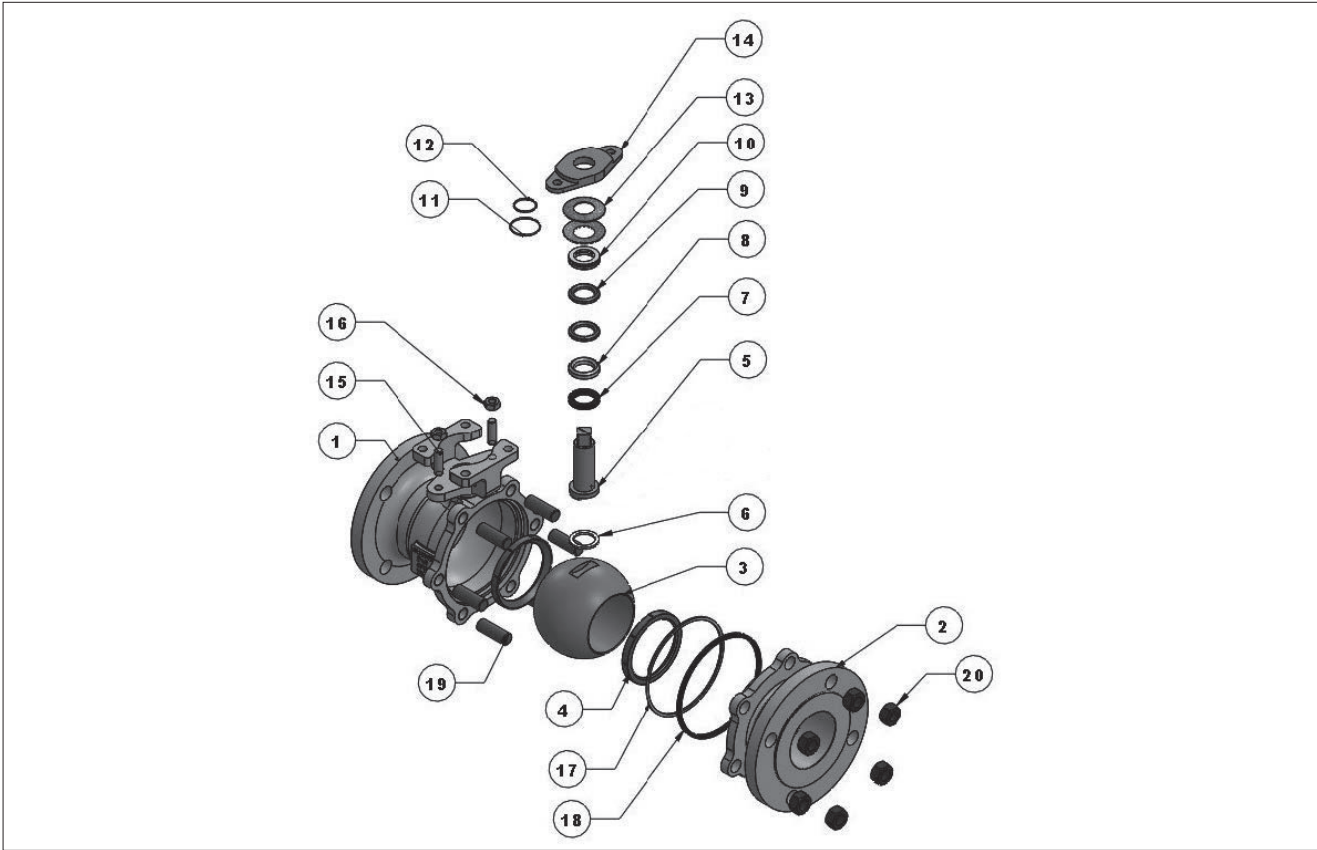

Bill of material and parts list

Part no.	Part name	Material	
		Carbon steel -22	Stainless steel -36
1	Body	ASTM A216 Gr. WCB	ASTM A351 Gr. CF8M
2	End piece	ASTM A216 Gr. WCB	ASTM A351 Gr. CF8M
3	Ball	316 Stainless steel	
4	Seat	TFM™ 1600	
5	Stem	316 Stainless steel	
6	Stem washer	Carbon filled PTFE	
7	Stem seal	Graphite	
8	Stem retainer 1	Glass filled PTFE	
9	V-ring stem seal	TFM™ 1600	
10	Stem retainer 2	Glass filled PTFE	
11	Outer stem O-ring	Fluoroelastomer (FKM)	
12	Inner stem O-ring	Fluoroelastomer (FKM)	
13	Disc spring	Spring steel	
14	Gland flange	ASTM A216 Gr. WCB	ASTM A351 Gr. CF8M
15	Gland stud	ASTM A193 Gr. B7	ASTM A193 Gr. B8M
16	Gland nut	ASTM A194 Gr. 2H	ASTM A194 Gr. 8M
17	Body seal	Fluoroelastomer (FKM)	
18	Body gasket	Graphite	
19	Body stud	ASTM A193 Gr. B7	ASTM A193 Gr. B8M
20	Body nut	ASTM A194 Gr. 2H	ASTM A194 Gr. 8M

Technical specifications

Rating /Nominal diameter:	ASME Class 150 DN15 – DN200 (NPS 1/2 – 8) ASME Class 300 DN15 – DN150 (NPS 1/2 – 6)	Leakage:	No visible leakage
Flange accommodation:	ASME B16.5	Standards followed:	ISO 17292, ASME B16.34, API 598, BS EN 12266, API 607, CE- PED 2014/68/EU
Face to face length:	ASME B16.10	Safety level:	SIL-3 capable
Vacuum rating:	29.91 inch Hg gauge (759.98 mm Hg gauge or 2×10^{-2} Torr or 4×10^{-4} psia or 99.99% vacuum)	Testing:	API 598

Flow data

The table at right provides flow coefficients for J9 series valves covered in this bulletin. C_v values represent the flow of water at +60°F through the valve in US gallons per minute at a pressure drop of 1 psi. The metric equivalent, K_v , is the flow of water at +16°C through the valve in cubic meters per hour at a pressure drop of 1 bar.

$C_v = 1.167 K_v$

Valve size		C_v	K_v
DN	NPS		
15	1/2	19	16
20	3/4	50	43
25	1	103	88
32	1 1/4	160	137
40	1 1/2	253	217
50	2	441	378
65	2 1/2	741	635
80	3	1,290	1,105
100	4	2,310	1,979
150	6	5,350	4,584
200	8	10,070	8,629

Valve body ratings

These are the maximum working pressure ratings of the valve body. The seat ratings, shown on the next page, determine the practical temperature and pressure limitations according to actual service conditions. Test pressures are recommended pressures for hydrostatic test with the valve ball half open.

Temperature °C	Maximum working pressure, barg			
	Class 150		Class 300	
	Carbon steel WCB	Stainless steel CF8M	Carbon steel WCB	Stainless steel CF8M
-29 to +38	19.6	19.0	51.1	49.6
100	17.7	16.2	46.6	42.2
150	15.8	14.8	45.1	38.5
200	13.8	13.7	43.8	35.7
250	12.1	12.1	41.9	33.4
Test pressure	30	29	77	75

Temperature °F	Maximum working pressure, psig			
	Class 150		Class 300	
	Carbon steel WCB	Stainless steel CF8M	Carbon steel WCB	Stainless steel CF8M
-20 to +100	285	275	740	720
200	260	235	680	620
300	230	215	655	560
400	200	195	635	515
500	170	170	605	480
Test pressure	450	425	1125	1100

Valve seat ratings

Seat ratings, indicated by solid line in the chart, are based on differential pressure with the valve ball in the fully closed position. The dotted lines indicate the maximum working pressures for WCB carbon steel valve bodies. The combination of dotted and solid lines indicates the maximum valve rating at specific pressure and temperature conditions. Carbon steel valves are rated to -29°C (-20°F). Low temperature limit for TFM™ seat and body seal O-ring is -30°C (-22°F).

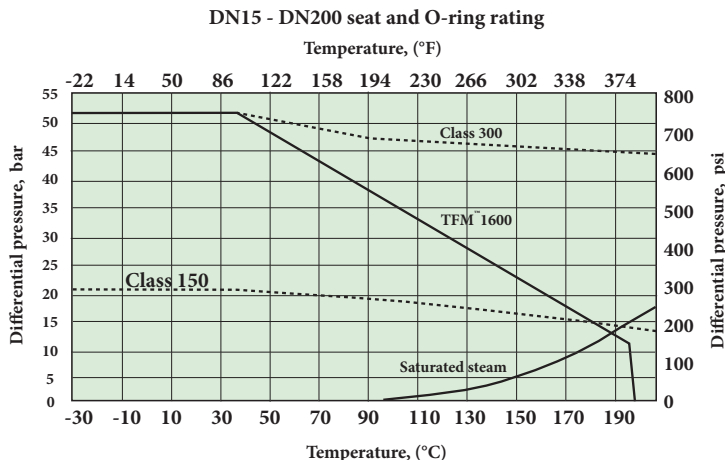

Valve torque data

Use this torque chart as a guide for actuator selection. The recommended minimum actuator torque includes a safety factor.

Valve size		Class 150		Class 300	
		Minimum actuator torque		Minimum actuator torque	
DN	NPS	N.m	lb-ft	N.m	lb-ft
15	1/2	6	5	8	6
20	3/4	8	6	10	8
25	1	9	7	11	9
32	1 1/4	16	12	20	15
40	1 1/2	23	17	28	21
50	2	30	23	38	29
65	2 1/2	48	36	78	58
80	3	66	49	108	80
100	4	144	107	192	142
150	6	372	275	540	399
200	8	600	443	-	-

Actuator selection

Selected rack and pinion actuator sizes in the chart are based on the recommended minimum actuator torque and 4 barg minimum air supply pressure. Selected spring return actuator size is suitable for fail open or fail close configuration. Unless otherwise specified, actuator will be set for fail close.

Actuators may be direct mounted or direct mounted with sleeve or mounted using bracket & coupler. For all these cases, the mounting sets include respective fasteners in addition to the above said components.

Valve size		Class 150		Class 300	
		Actuator, 4 barg min. air supply		Actuator, 4 barg min. air supply	
DN	NPS	RNP DA	RNP SR	RNP DA	RNP SR
15	1/2	RNP 40	RNP 50 SR 40	RNP 40	RNP 50 SR 40
20	3/4	RNP 40	RNP 50 SR 40	RNP 40	RNP 63 SR 40
25	1	RNP 40	RNP 63 SR 40	RNP 40	RNP 63 SR 40
32	1 1/4	RNP 50	RNP 80 SR 40	RNP 63	RNP 80 SR 40
40	1 1/2	RNP 63	RNP 80 SR 40	RNP 63	RNP 90 SR 40
50	2	RNP 63	RNP 90 SR 40	RNP 63	RNP 90 SR 40
65	2 1/2	RNP 80	RNP 100 SR 40	RNP 90	RNP 125 SR 40
80	3	RNP 90	RNP 110 SR 40	RNP 100	RNP 125 SR 40
100	4	RNP 100	RNP 150 SR 40	RNP 125	RNP 175 SR 40
150	6	RNP 150	RNP 250 SR 40	RNP 175	RNP 250 SR 40
200	8	RNP 175	RNP 300 SR 40	-	-

Hand lever

Valve size		Class	Hand lever code	Mounting set number
DN	NPS			
15	1/2	150 & 300	RHL 0815036	EASYFLOW MOUNTING SET 69
20	3/4	150 & 300	RHL 0915036	EASYFLOW MOUNTING SET 69
25	1	150 & 300	RHL 0915036	EASYFLOW MOUNTING SET 69
32	1 1/4	150 & 300	RHL 0915036	EASYFLOW MOUNTING SET 69
40	1 1/2	150 & 300	RHL 1115036	EASYFLOW MOUNTING SET 70
50	2	150 & 300	RHL 1420036	EASYFLOW MOUNTING SET 71
65	2 1/2	150 & 300	RHL 1420036	EASYFLOW MOUNTING SET 71
80	3	150 & 300	RHL 1725036	EASYFLOW MOUNTING SET 94
100	4	150 & 300	RHL 1725036	EASYFLOW MOUNTING SET 94

Actuator mounting set

Class 150 (J915)		
Valve size	Actuator model	Mounting set number
DN15 (1/2)	RNP 40	EASYFLOW MOUNTING SET 54
	RNP 50	EASYFLOW MOUNTING SET 54
DN20 (3/4)	RNP 40	EASYFLOW MOUNTING SET 12
	RNP 50	EASYFLOW MOUNTING SET 12
DN25 (1)	RNP 40	EASYFLOW MOUNTING SET 53
	RNP 63	EASYFLOW MOUNTING SET 41
DN32 (1.1/4)	RNP 50	EASYFLOW MOUNTING SET 53
	RNP 80	EASYFLOW MOUNTING SET 34
DN40 (1.1/2)	RNP 63	EASYFLOW MOUNTING SET 14
	RNP 80	EASYFLOW MOUNTING SET 31
DN50 (2)	RNP 63	EASYFLOW MOUNTING SET 221
	RNP 90	EASYFLOW MOUNTING SET 15
DN65 (2.1/2)	RNP 80	EASYFLOW MOUNTING SET 15
	RNP 100	EASYFLOW MOUNTING SET 16
DN 80 (3)	RNP 90	EASYFLOW MOUNTING SET 37
	RNP 110	EASYFLOW MOUNTING SET 17
DN 100 (4)	RNP 100	EASYFLOW MOUNTING SET 17
	RNP 150	EASYFLOW MOUNTING SET 19
DN 150 (6)	RNP 150	EASYFLOW MOUNTING SET 226
	RNP 250	EASYFLOW MOUNTING SET 32
DN 200 (8)	RNP 175	EASYFLOW MOUNTING SET 229
	RNP 300	EASYFLOW MOUNTING SET 230

Class 300 (J930)		
Valve size	Actuator model	Mounting set number
DN15 (1/2)	RNP 40	EASYFLOW MOUNTING SET 33
	RNP 50	EASYFLOW MOUNTING SET 33
DN20 (3/4)	RNP 40	EASYFLOW MOUNTING SET 12
	RNP 63	EASYFLOW MOUNTING SET 13
DN25 (1)	RNP 40	EASYFLOW MOUNTING SET 53
	RNP 63	EASYFLOW MOUNTING SET 41
DN32 (1.1/4)	RNP 63	EASYFLOW MOUNTING SET 60
	RNP 80	EASYFLOW MOUNTING SET 61
DN40 (1.1/2)	RNP 63	EASYFLOW MOUNTING SET 62
	RNP 90	EASYFLOW MOUNTING SET 63
DN50 (2)	RNP 63	EASYFLOW MOUNTING SET 221
	RNP 90	EASYFLOW MOUNTING SET 15
DN65 (2.1/2)	RNP 90	EASYFLOW MOUNTING SET 15
	RNP 125	EASYFLOW MOUNTING SET 73
DN 80 (3)	RNP 100	EASYFLOW MOUNTING SET 17
	RNP 125	EASYFLOW MOUNTING SET 17
DN 100 (4)	RNP 125	EASYFLOW MOUNTING SET 17
	RNP 175	EASYFLOW MOUNTING SET 64
DN 150 (6)	RNP 175	EASYFLOW MOUNTING SET 227
	RNP 250	EASYFLOW MOUNTING SET 228

Dimensions

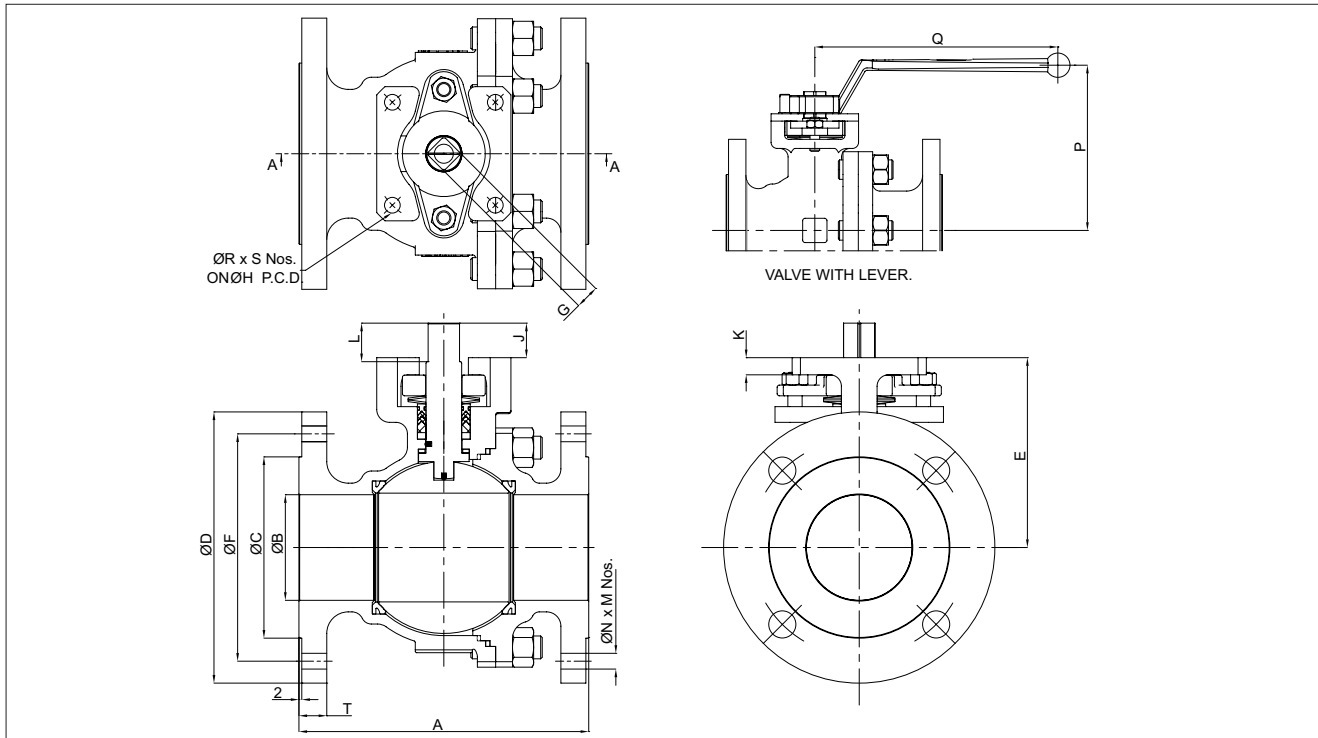

Valve size		Class 150 (J915)																			
DN	NPS	Dimensions (mm)																	Weight (kg)		
		A	T	ØB	ØC	ØD	G	ØF	ØN	M	J	K	L	E	ØH	ISO 5211	ØR	S		P	Q
15	1/2	108	10	14	34.9	90	8	60.3	15.9	4	3	5	10.5	46	50	F05	M6	4	68	150	1.9
20	3/4	117	10.9	19.1	42.9	100	9	69.9	15.9	4	8.5	6.5	10.5	52.5	50	F05	M6	4	81	150	2.4
25	1	127	11.6	25.4	50.8	110	9	79.4	15.9	4	10.3	6.5	12	57.8	50	F05	M6	4	85	150	3.2
32	1 1/4	140	13.2	32	63.5	115	9	88.9	15.9	4	10.5	6	12	64.6	50	F05	M6	4	95	150	4
40	1 1/2	165	14.7	38.1	73	125	11	98.4	15.9	4	15.3	6	17	77.7	50	F05	Ø8	4	106	150	5.1
50	2	178	16.3	50.8	92.1	150	14	120.7	19.1	4	18.2	6	21.5	96	70	F07	Ø9	4	137	200	9.1
65	2 1/2	190	17.9	64.1	104.8	180	14	139.7	19.1	4	18.5	6	21.5	105.8	70	F07	Ø9	4	146	200	13.8
80	3	203	19.5	76.2	127	190	17	152.4	19.1	4	24.2	12	27	133	102	F10	Ø11	4	168	250	18.1
100	4	229	24.3	102	157.2	230	17	190.5	19.1	8	23.5	12	26.3	153	102	F10	Ø11	4	190	250	32.9
150	6	267*	25.9	150.8	215.9	280	22	241.3	22.4	8	44	13	47	207	125	F12	Ø13	4	#	#	66.5
200	8	292*	29	203	269.9	345	27	298.5	22.4	8	54.9	13	48	255	140	F14	Ø18	4	#	#	110.5

* Dimensions are for short pattern

Gear operated valves

Valve size		Class 300 (J930)																			
DN	NPS	Dimensions (mm)																	Weight (kg)		
		A	T	ØB	ØC	ØD	G	ØF	ØN	M	J	K	L	E	ØH	ISO 5211	ØR	S		P	Q
15	1/2	140	14.7	12.7	34.9	95	8	66.7	15.9	4	0.7	5	11	38.3	50	F05	M6	4	68	150	1.9
20	3/4	152	16.3	19.1	42.9	115	9	82.6	19.1	4	8.5	6.5	10.5	52.5	50	F05	M6	4	81	150	2.4
25	1	165	17.9	25.4	50.8	125	9	88.9	19.1	4	10.3	6.5	12	57.8	50	F05	M6	4	85	150	3.4
32	1 1/4	178	19.5	32	63.5	135	9	98.4	19.1	4	10.5	6	12	64.6	50	F05	M6	4	95	150	4.6
40	1 1/2	190	21.1	38	73	155	11	114.3	22.4	4	13.3	6	17	80	50	F05	Ø8	4	106	150	9.2
50	2	216	22.7	50.8	92.1	165	14	127	19.1	8	18.3	6	21.5	96	70	F07	Ø9	4	137	200	12.8
65	2 1/2	241	26.9	62	104.8	190	14	149.2	22.4	8	18.8	6	21.5	105.8	70	F07	Ø9	4	146	200	19.5
80	3	282	29	76.2	127	210	17	168.3	22.4	8	24	12	27	133	102	F10	Ø11	4	168	250	27.2
100	4	305	32.2	102	157.2	255	17	200	22.4	8	23.5	12	26.3	153	102	F10	Ø11	4	190	250	45.0
150	6	403*	37	150.8	215.9	320	22	269.9	22.4	12	71.5	16	47	179.5	125	F12	Ø13	4	#	#	110.5

* Dimensions are for short pattern

Gear operated valves

How to order

1.	2.	3.	4.	5.	6.	7.	8.	9.
50	J9	15	22	36	36	ZG	53	

1.	Size, DN (NPS ref.)
15	15 (1/2)
20	20 (3/4)
25	25 (1)
32	32 (1 1/4)
40	40 (1 1/2)
50	50 (2)
65	65 (2 1/2)
80	80 (3)
100	100 (4)
150	150 (6)
200	200 (8) ^{Note 1}

Note 1: Class 150 only

2.	Series
J9	

3.	Flange / rating
15	ASME Class 150
30	ASME Class 300

4.	Body material
22	Carbon steel (WCB)
36	Stainless steel (CF8M)

5.	Ball material
36	316 Stainless steel

6.	Stem material
36	316 Stainless steel
43	17-4PH Stainless steel

7.	Seat and seal materials
ZG	TFM™ 1600 / Graphite

8.	O-Ring material
53	Fluoroelastomer FKM

9.	Options
-	Blank, standard option
Q	Cavity filler seat

TFM™ is a trademark of Dyneon, a 3M Company

NOTE:

As the use of the valve is application specific, a number of factors should be taken into account when selecting a valve for a given application. Therefore, some of the applications in which the valves are used are outside the scope of this document. If you have any questions concerning the use, application or compatibility of the valve with the intended service, contact nearest Valmet sales office for more information.

Valmet Flow Control Oy

Vanha Porvoontie 229, 01380 Vantaa, Finland.

Tel. +358 10 417 5000.

www.valmet.com/flowcontrol

Subject to change without prior notice.

Neles, Neles Easyflow, Jamesbury, Stonel, Valvcon and Flowrox, and certain other trademarks, are either registered trademarks or trademarks of Valmet Oyj or its subsidiaries in the United States and/or in other countries.

For more information www.neles.com/trademarks

